

Sakurai



PST-80/104

High cost performance Automatic Pile Stacker

This Stacker is set after the dryer of Screen printing and it keep stacking the products.

The operation is simple and it stacks wide range of substrates without damaging printed surface in speedily and accurately.

- Rigid construction of cast iron frame.
- Maximum speed of 3,600 sheets per hour.
- Stable conveyance by two kinds, total of 4 belts.

Sakurai Pile Stacker PST series

| | | PST-80 | PST-104 |
|--------------------|---------|-------------------|-------------------|
| Max. stock size | (mm) | 800×550 | 1,020×740 |
| Max. pile height | (mm) | 750 | 750 |
| Pass line height | (mm) | 850 | 850 |
| Air required | (L/min) | 30 | 30 |
| Dimensions (L×W×H) | (mm) | 1,620×1,592×1,216 | 1,638×1,860×1,225 |
| Machine weight | (kg) | 550 | 650 |
| Power | (KW) | 1.5 | 1.5 |

[Major equipment]

- Palletized sheet pile
- Rear way delivery
- Side jogger timing selection
- Four conveyor belt
- Air blow up device
- Air blow sheet separator
- Delivery mirror

[Floor Plan]

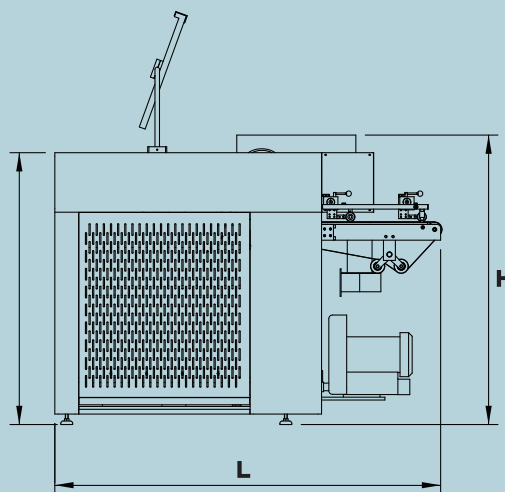
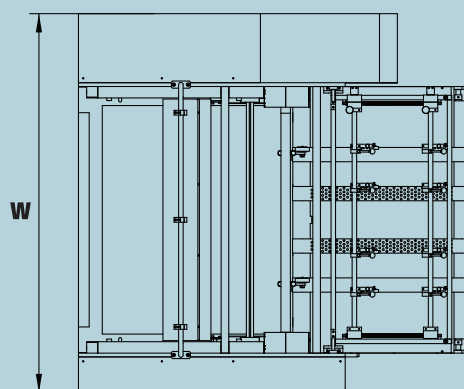

| | L : Long | W : Width | H : Height |
|---------|----------|-----------|------------|
| PST-80 | 1,620mm | 1,592mm | 1,216mm |
| PST-104 | 1,638mm | 1,860mm | 1,225mm |

Superlative products to guarantee clients satisfaction

*The specifications given are as of September 2012 and are subject to further change for improvement.

Sakurai
Sakurai Graphic Systems Corp.
<http://www.sakurai-gs.co.jp>

Headquarters 2-2-9 Fukuzumi, Koto-ku, Tokyo 135-0032, Japan
Tel: 81-3-3643-1131 Fax: 81-3-3641-9663 E-mail: info@sakurai-gs.co.jp
London Branch Cherrywell House, Tamian Way, Hounslow, Middlesex TW4 6BL UK
Tel: 44-20-8577-5672 Fax: 44-20-8572-3942 E-mail: admin@sakurai.co.uk
Sakurai USA Inc. 1700 North Basswood Road, Schaumburg, IL 60173, USA
Tel: 1-847-490-9400 Fax: 1-847-490-4200 E-mail: sales@sakurai.com



ISO 9001,14001
PRODUCTION & TECHNOLOGY DEPT.