

**Sakurai**

Full Automatic High Precision Rotary, Stop Cylinder Screen Press

# MAESTRO SERIES

MS-80A II

MS-102AX



MS-102AX

The combination of high precision and productivity - Fully Automatic Ultra-High Precision Rotary, Stop Cylinder Screen Press

# MAESTRO SERIES

Designed to meet the ever increasing demands in the field of industrial and commercial screen printing, Sakurai manufactures high-speed, high-quality stop-cylinder fully automatic screen printing presses. In the field of commercial screen printing, it is used for advertisements requiring long life and sharpness which is a main characteristic of screen printing and in addition for printing on stock produced on offset press. In the field of industrial printing, it is highly suited to printing on many kind of films for electric, electron, motor vehicle and other products. We highly recommend our Maestro series screen print machine with half a century of fully automatic cylinder manufacture experience technology behind it.



Operating Panel

Applied an intensive keyboard system so that anyone can use it safely and accurately, and it is placed in a location that is easy to operate. Also, the emergency stop button is placed in a location with good access considering safety. Symbols that comply with ISO standards are adopted for panel display.

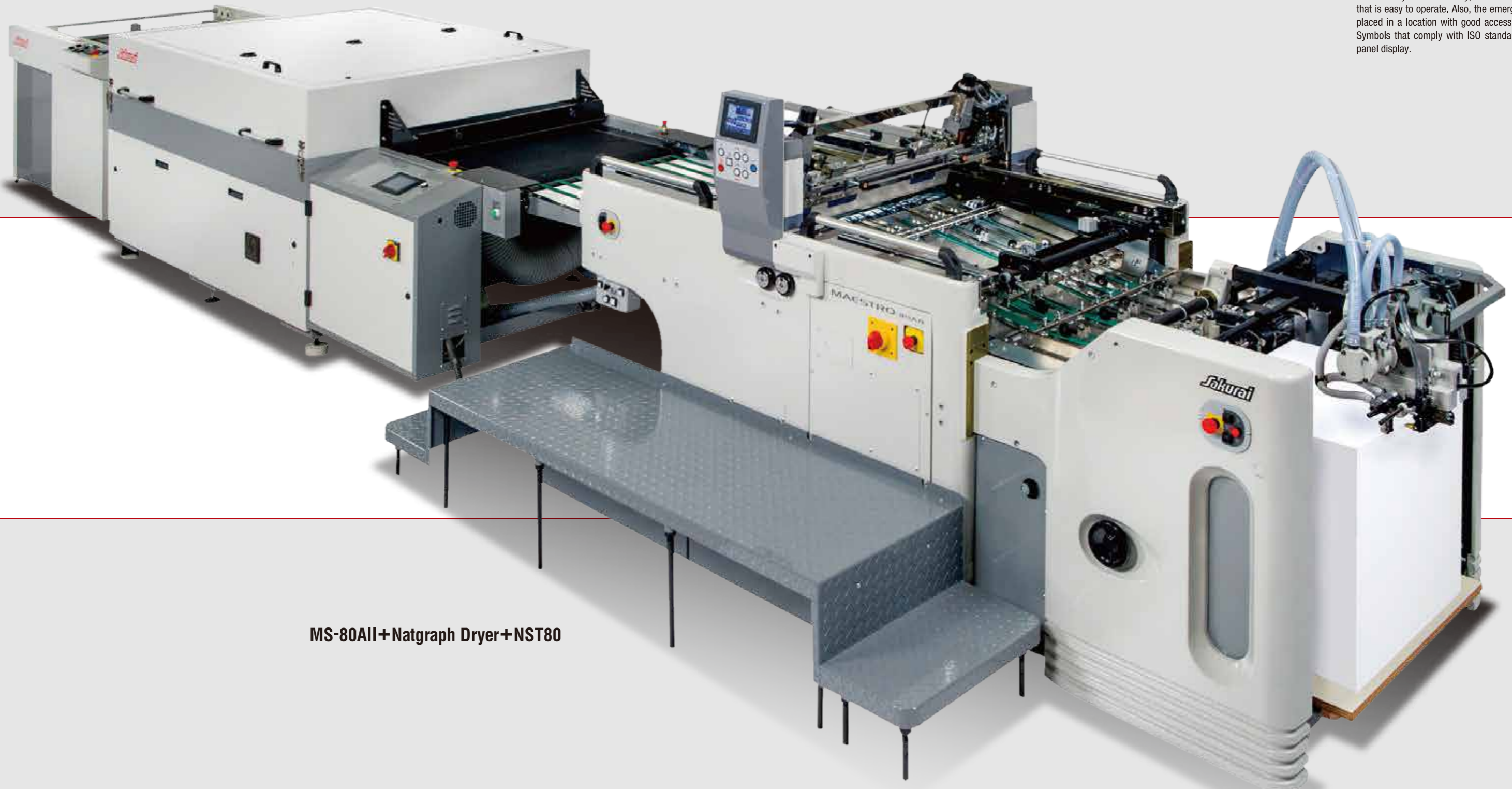

MS-80All+Natgraph Dryer+NST80



### Feeder

Sakurai's original rear pick-up feeder, with technology taken from the offset press, ensures stable and smooth feeding of various types of substrate. Dependant on the substrate, overlapped (stream) or single sheet (universal) feed can be selected easily. A front pick up feeder is also available and can be used for stable feeding of film and other substrates.



### Feed board

The press allows a large variety of print substrate to be handled as the feed board surface is designed to minimise scratching and static electricity build up during the transport of the substrate. It is ideally suited for printing graphics, packaging, labels, ceramic transfers, membranes, film printing, and much more.

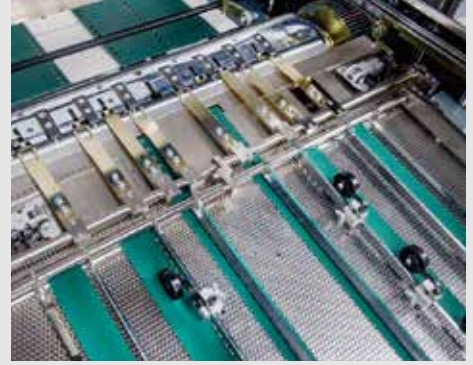

### Stop cylinder

The non-reciprocating, stop motion cylinder system ensures perfect registration and high quality printing. The cylinder is stationary at the point when the grippers take the substrate at the start of the print stroke. The stop motion occurs on every print cycle and prevents damage to the edge of substrate.

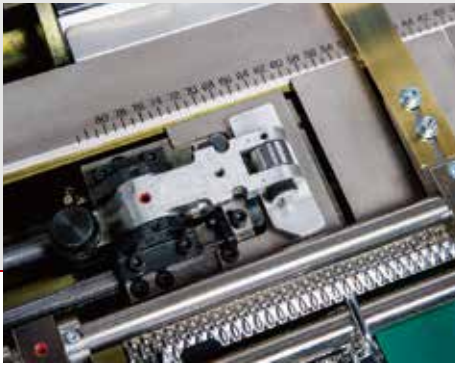

### Registration

Bearing type side register system is applied. (MS102AX : Pull/push type, MS80All : Pull type) Cylinder built-in front lay sensors and side lay sensors are in standard so the perfect registration can be assured.



### Screen frame pneumatic lock clamp

Simple toggle switch air cylinder clamps are fitted to the master frame carrier to hold the aluminum screen frame in position instantly and securely. Fine registration can be obtained with the micro adjuster knobs.



### Squeegee head & cylinder

The squeegee and flood-coater are driven by individual cams, and a two-step action cam helps reduce the squeegee shock onto the screen mesh. Due to the positive down cam action, the printing pressure is evenly applied to the cylinder continuously, resulting in sharp dot reproduction and perfect solid printing. The vacuum cylinder with +/-0.01mm accuracy across the cylinder surface, a large cylinder shaft and specially made high precision bearings ensure the highest quality printing at higher speed.

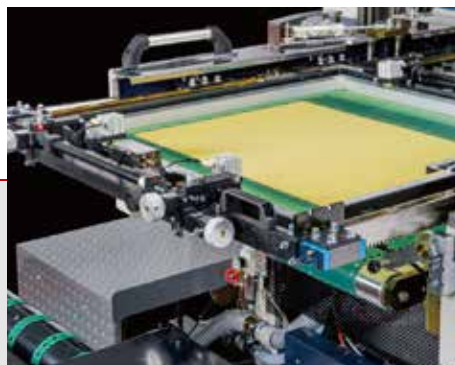

### Screen frame pull-out

The screen frame can be unlocked and pulled out to the delivery end of the press so that feed position of substrate can be checked, readjusted and corrected. There is no need for registration adjustment as it will return to the same position when the screen frame is returned to the print position.

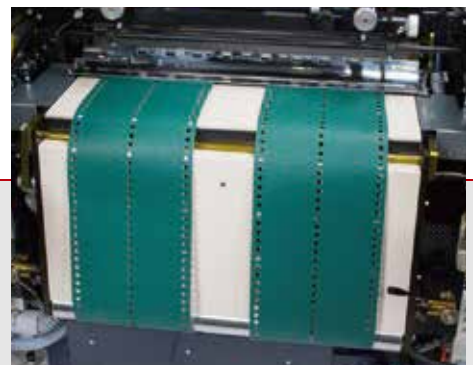

### Delivery board lowering device

The delivery board can be lowered by 90 degrees to allow easy access to the screen mesh for cleaning or to the squeegee and flood coater for fixing and unfixing. The delivery belts are 280mm wide and transport the substrate straight and true.

WHY “STOP” CYLINDER can achieve perfect accuracy in printing?

# BECAUSE the substrate is gripped only while the cylinder stops, resulting in no sheet movement

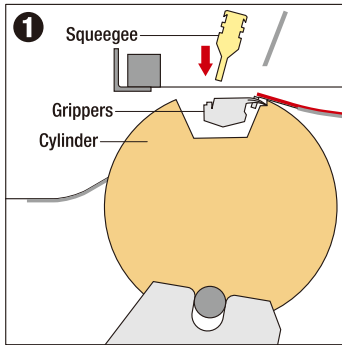

1 The grippers hold a substrate at the right position while the cylinder stops. Then the squeegee moves down onto the screen.

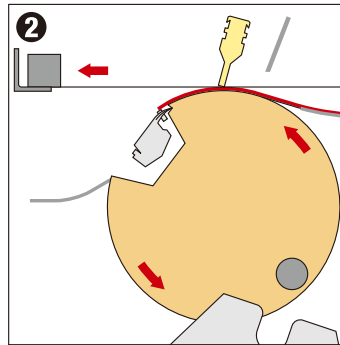

2 The squeegee moves down and printing starts at the top of the cylinder. The screen frame moves and the vacuum cylinder rotates.

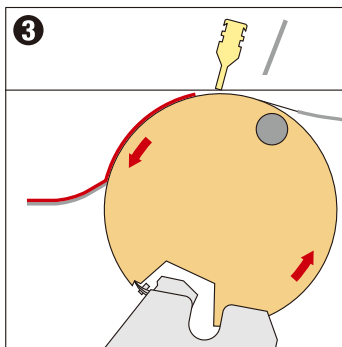

3 The substrate is delivered after being released by the grippers. The cylinder continues to rotate after the substrate is delivered.

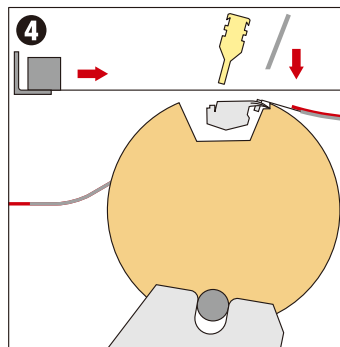

4 The screen frame starts moving back. The flo-coater starts moving down onto the screen when the squeegee lifts up. The cylinder keeps rotating for printing the next substrate.

## MACHINE DIMENSIONS

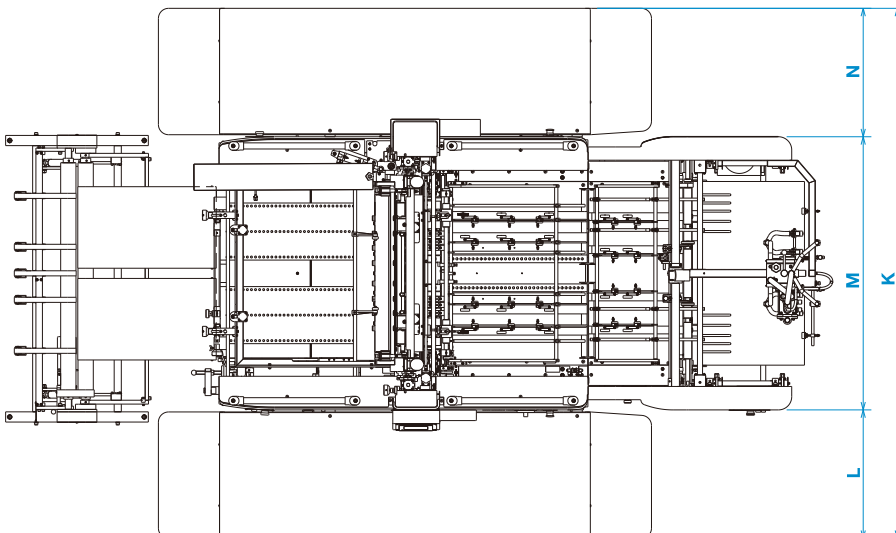
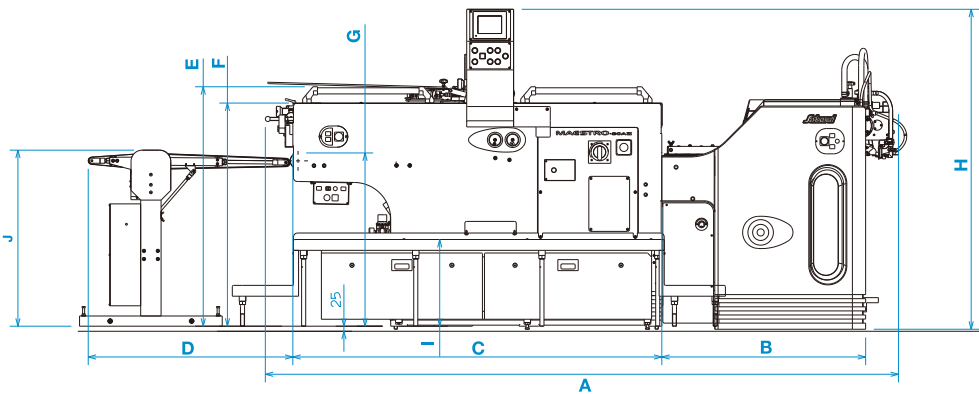

	MS-80All	MS-102AX
A	3106	3907
B	1000	1226
C	1810	2345
D	1065	1098
E	1175	1228
F	1095	1125
G	850	869
H	1570	1610
I	425	387
J	864	905
K	2600	3080
L	630	630
M	1340	1820
N	630	630

(unit : mm)

## MAJOR SPECIFICATIONS

Model		MS-80AII	MS-102AX
Feeder: Selection		Rear pick up feeder / Front pick up feeder	Rear pick up feeder / Front pick up feeder
Max. sheet size (WxL)	mm	800×550 (31½ × 21¾")	1,050×750 (41½ × 29½")
Min. sheet size (WxL)	mm	350×270 (13⅞ × 10⅝")	Single feeding: 420×297 (16⅝ × 11¾") Stream feeding: 560×350 (22⅛ × 13⅞")
Ext. screen frame size (WxL): Selection	mm	880×880 (34¾ × 34¾")	930×880 (36¾ × 34¾")
Max. print size (WxL)	mm	720×520 (28⅜ × 20½")	770×520 (30⅜ × 20½")
Sheet thickness (*)	mm	0.05~0.8 (0.001~0.031")	0.075~0.8 (0.002~0.031")
Printing speed	IPH	400~4,000 / 400~3,000	800~4,000 / 800~3,000
Machine dimensions (LxWxH)	mm	3,106×2,600×1,570 (122¼ × 102⅜ × 61¾")	3,907×3,080×1,610 (153⅓ × 121⅞ × 63⅝")
Machine weight	kg	3,450	5,200
Power consumption	kW	5.7	10.7

(\*) Depends on the kind of printing substrates and conditions, figures may be changed.

### STANDARD ACCESSORIES

- Embossed stainless steel plate feeder board
- Press down feed rollers and brushes
- Pull side lay (80A II)
- Push/pull convertible side lays (R+L) (102AX)
- Delivery board belt motor drive
- Delivery board lowering system
- Built-in front lay sensor
- Suction feed belts
- Dripless squeegee
- Screen frame pull-out device
- Screen frame air clamp device
- Ink drip pan (at frame pull-out)
- Motorized squeegee pressure control
- Inverter speed control device (Digital indication)
- Preset counter
- Fixed rebound stopper (feeder side)
- Fixed rebound stopper (delivery side)

### OPTIONAL EQUIPMENT

- Double sheet detector (Mechanical/Ultra-sonic)
- Piston sucker (Front pick-up feeder)
- Push side lay (80A II)
- Variety anti-static devices
- Sheet feed ball rack
- Movable rebound stopper
- Sheet cleaning roller unit (one side/both side)
- Smaller cyl. Vacuum holes (102AX)
- Screen part tensioners
- Cross over stand
- Air compressor (0.4kW)
- High pile (+300mm)
- Paletttable feeder
- Smart cover

\*The information on this catalogue contains patented technology and under patent fillings.

\*The manufacturer reserves the right to change without any prior notice, any of the followings as related to products listed in subject catalogue.

(1) Improvement in safety, performance or functions (2) Improvement in designed quality

\*The denoted speeds are indicative of the mechanically possible performance. Printing speeds are subject to variation according to the plates and substrates to be used.

\*Photographs appearing in this catalogue include some optional equipments.

\*The specifications given are as of October 2021 and are subject to further change for improvement together with the content of the photographs.

### Superlative products to guarantee clients satisfaction

**Sakurai**  
Sakurai Graphic Systems Corp.  
<https://www.sakurai-gs.co.jp>

Headquarters 2-2-9 Fukuzumi, Koto-ku, Tokyo 135-0032, Japan  
Tel: 81-3-3643-1131 Fax: 81-3-3641-9663 E-mail: info@sakurai-gs.co.jp  
European Branch Wayenborgstraat 13, 2800 Mechelen, Belgium  
Tel: 32-15-286-800  
Sakurai USA, Inc. 1700 North Basswood Road, Schaumburg, IL 60173, USA  
Tel: 1-847-490-9400 Fax: 1-847-490-4200 <http://sakurai.com>

